



FIRE-RATED STEEL DOORS



By:  **alitco**
الدريس AIDREES | الينكو

Introductions

ALDREES group is a name that has been tied to the world of Fuel station construction and Building Material Division for decades. To many, it has become the first name that comes to mind when Petroleum Services in Saudi Arabia or the Arabian world are mentioned. The group was started in 1920 known as Mohammed Saad ALDREES and Sons Company Limited. To invest in the sectors of Industrial & Trading under the leadership of Sheikh Mohammed Saad ALDREES. Over five decades, the group's projects expanded to become one of the largest Saudi companies in several sectors include AICS Division, Tools & Equipment Sector, Real Estate Developing. The business of "ALITCO" has expanded and to work with the largest and most recent projects spread in Saudi Arabia.

ALITCO BUSINESS Sectors



Industrial Sector



Electromechanical Sector



Real Estate Sector



Agriculture Sector

Aics Division

ALDREES International Contracting Supplies "AICS" One of the divisions of ALDREES Industrial & Trading Co. (ALITCO). As Group of Companies cratering to the construction industry in Saudi Arabia since 1978. Since is inception the AICS Division has offered the construction industry the best in Hollow Metal Doors and Frames representing a well known international companies up to 2003. Now we are proud to introduce a new legend in Hollow Metal Doors and Frames with Steel Tech Doors & Frames manufactured and Wooden doors and Frames manufactured by our Factories in Riyadh over 10,500 Sqm. The development Of Steel Tech in Based on our years of experience in custom door, frames and hardware's, supplying countless prestigious project throughout Saudi Arabia



Certificates



ISO Certificate



Intertek Certificate



UL Certificate



Certificate of Approval

This is to certify that the Management System of
Aldrees Industrial Trading Co.

Raf Commercial Complex Omar Al Muhtar, - Raf Street, Riyadh, 2049, Saudi Arabia

has been approved by LRQA to the following standards:
ISO 9001:2015

Basem Obaid - Global Head of Training and Improvement Services
Issued by: Lloyd's Register Egypt LLC
for and on behalf of: Lloyd's Register Quality Assurance Limited

Current issue date: 24 May 2019
Expiry date: 23 May 2022
Certificate identity number: 10195567

Original approval(s):
ISO 9001 - 24 May 2019

Approval number(s): ISO 9001 - 00020441

The scope of this approval is applicable to:
Manufacture and sales of metal and wooden doors & frames, fabricating, sales and installation of toilet partitions, and sales of building finishing material including door ironmongery & supply, installation, commissioning and after sales services of tools and equipment for workshops, garages, fuel stations, and industries.



Certificate of Compliance



You have been awarded
**Intertek WH US Mark for Category A -
Doors - No Additional Edge-sealing
System Required**

Standards: UL 1099 (2015), UL 1099 (2015), NFPA 252 (2011)

Certificate number: WH121-23533900

Organization: Aldrees Industrial & Trading Co. (ALITCO)
P.O. Box 15273
Riyadh 11444
Kingdom of Saudi Arabia

Product: Aldrees - Latched Single Acting Steel Fire Door With "C-
Channel" Sill/Fenestration - 180 Minutes - UL 190C
Spec ID: 9830
Fire Rating: 90 Min PP Category A Door, 3 Hour PP Category A Door, 2 Hour PP Category A Door, 90 Min PP Category A Door
Listing Information: See following page(s)

Certification body: Intertek Testing Services NA, Inc.
Initial registration: September 30, 2021
Date of expiry: December 31, 2022
Issue status: 2

Authorized By:
Jean-Philippe Kaye, Director of Certification

Intertek Testing Services NA, Inc.
540 E. Algonquin Road, Ste H, Algonquin Heights, IL 60005 USA
Phone: 847-439-5667 Fax: 847-439-7336

www.intertek.com



Certificate of Compliance



You have been awarded
**Intertek WH US Mark for Category A -
Doors - No Additional Edge-sealing
System Required**

Standards: UL 1099 (2015), UL 1099 (2015), NFPA 252 (2011)

Certificate number: WH121-23533900

Organization: Aldrees Industrial & Trading Co. (ALITCO)
P.O. Box 15273
Riyadh 11444
Kingdom of Saudi Arabia

Product: Aldrees - Latched Single Acting Steel Fire Door With "Hot
Channel" Sill/Fenestration - 180 Minutes - UL 190C
Spec ID: 9830
Fire Rating: 90 Min PP Category A Door, 3 Hour PP Category A Door, 2 Hour PP Category A Door, 90 Min PP Category A Door
Listing Information: See following page(s)

Certification body: Intertek Testing Services NA, Inc.
Initial registration: September 30, 2021
Date of expiry: December 31, 2022
Issue status: 2

Authorized By:
Jean-Philippe Kaye, Director of Certification

Intertek Testing Services NA, Inc.
540 E. Algonquin Road, Ste H, Algonquin Heights, IL 60005 USA
Phone: 847-439-5667 Fax: 847-439-7336

www.intertek.com

The certificate of compliance is valid only for the products and services specified in the scope of this approval. The certificate is issued by Intertek Testing Services NA, Inc. and is subject to the terms and conditions of the Intertek Testing Services NA, Inc. Certification Agreement. The certificate is issued on the condition that the certificate holder will maintain the certificate holder's compliance with the requirements of the applicable standards and will provide access to the certificate holder's records to the certificate holder's customers. The certificate holder is responsible for the accuracy of the information provided in this certificate. The certificate holder is also responsible for the accuracy of the information provided in this certificate. The certificate holder is also responsible for the accuracy of the information provided in this certificate. The certificate holder is also responsible for the accuracy of the information provided in this certificate.



Certificate of Compliance



You have been awarded
**Intertek WH US Mark for Category C -
Standard Frames**

Standards: NFPA 252 (2011), UL 1099 (2015)

Certificate number: WH121-23533907

Organization: Aldrees Industrial & Trading Co. (ALITCO)
P.O. Box 15273
Riyadh 11444
Kingdom of Saudi Arabia

Product: Aldrees Category C - Standard Frames
Spec ID: 2088
Listing Information: See following page(s)

Certification body: Intertek Testing Services NA, Inc.
Initial registration: January 01, 2013
Date of expiry: December 31, 2022
Issue status: 5

Authorized By:
Jean-Philippe Kaye, Director of Certification

Intertek Testing Services NA, Inc.
540 E. Algonquin Road, Ste H, Algonquin Heights, IL 60005 USA
Phone: 847-439-5667 Fax: 847-439-7336

www.intertek.com



You have been awarded:
Intertek WH US Mark for Security Fire Door & Frame Assemblies
Standards: NFPA 252 (2005), UL 10C (2008), ASTM F1400 (2008), NFPA 252 (2012)

Certificate number: WH13-2353905

Organization: Aldrees Industrial & Trading Co. (ALITCO)
P.O. Box 15273
Riyadh 11444
Kingdom of Saudi Arabia

Product: Aldrees Industrial Security Fire Door & Frame Assemblies
See ID 3038
Using Information See following pages

Certification body: Intertek Testing Services NA, Inc.
Initial registration: January 01, 2013
Date of expiry: December 31, 2022
Issue status: 5

Authorized By:
Jean-Philippe Kayl
Jean-Philippe Kayl, Director of Certification

Intertek Testing Services NA, Inc.
545 E. Gillespie Road, Ste M, Alhambra Heights, IL 60005 USA
Phone: 631-439-3587 Fax: 631-439-7329

www.intertek.com

This certificate is only valid when used in conjunction with the product(s) specified on this certificate and is not a substitute for the product's technical specifications. The holder of this certificate is responsible for ensuring that the product(s) remains in compliance with the requirements of the certificate. The certificate holder is not responsible for the safety of the product(s) or for any damage or injury caused by the product(s). The certificate holder is not responsible for the safety of the product(s) or for any damage or injury caused by the product(s). The certificate holder is not responsible for the safety of the product(s) or for any damage or injury caused by the product(s). The certificate holder is not responsible for the safety of the product(s) or for any damage or injury caused by the product(s).



You have been awarded:
Intertek WH US + C Mark for Category A - Doors - No Additional Edge-sealing System Required
Standards: UL 10C (1985), CWI 156 (1984), NFPA 252 (1995), UL 10C (2008), CWI 156 (2009)

Certificate number: WH13-2353904

Organization: Aldrees Industrial & Trading Co. (ALITCO)
P.O. Box 15273
Riyadh 11444
Kingdom of Saudi Arabia

Product: Steel Tech 3 Hour Honeycomb Core Fire Door whose P/HP
See ID 3041
Fire Rating: 30 Min without Pressure, 1 Hour Insulated Pressure, 3 Hour PP Category A Door, 20 Min without Pressure, 30 Min without Pressure, 30 Min without Pressure, 30 Min without Pressure
Using Information See following pages

Certification body: Intertek Testing Services NA, Inc.
Initial registration: January 01, 2013
Date of expiry: December 31, 2022
Issue status: 5

Authorized By:
Jean-Philippe Kayl
Jean-Philippe Kayl, Director of Certification

Intertek Testing Services NA, Inc.
545 E. Gillespie Road, Ste M, Alhambra Heights, IL 60005 USA
Phone: 631-439-3587 Fax: 631-439-7329

www.intertek.com

This certificate is only valid when used in conjunction with the product(s) specified on this certificate and is not a substitute for the product's technical specifications. The holder of this certificate is responsible for ensuring that the product(s) remains in compliance with the requirements of the certificate. The certificate holder is not responsible for the safety of the product(s) or for any damage or injury caused by the product(s). The certificate holder is not responsible for the safety of the product(s) or for any damage or injury caused by the product(s). The certificate holder is not responsible for the safety of the product(s) or for any damage or injury caused by the product(s). The certificate holder is not responsible for the safety of the product(s) or for any damage or injury caused by the product(s).



You have been awarded:
Intertek WH US Mark for Doors
Standards: UL 10C (1985), NFPA 252 (1995), NFPA 252 (2005)

Certificate number: WH13-2353903

Organization: Aldrees Industrial & Trading Co. (ALITCO)
P.O. Box 15273
Riyadh 11444
Kingdom of Saudi Arabia

Product: Steel Tech 3 Hour Polyurethane Core Fire Door whose NP
See ID 3267
Fire Rating: 45 Min Insulated Pressure, 30 Min Insulated Pressure, 30 Min Insulated Pressure, 30 Min Insulated Pressure
Using Information See following pages

Certification body: Intertek Testing Services NA, Inc.
Initial registration: January 01, 2013
Date of expiry: December 31, 2022
Issue status: 5

Authorized By:
Jean-Philippe Kayl
Jean-Philippe Kayl, Director of Certification

Intertek Testing Services NA, Inc.
545 E. Gillespie Road, Ste M, Alhambra Heights, IL 60005 USA
Phone: 631-439-3587 Fax: 631-439-7329

www.intertek.com

This certificate is only valid when used in conjunction with the product(s) specified on this certificate and is not a substitute for the product's technical specifications. The holder of this certificate is responsible for ensuring that the product(s) remains in compliance with the requirements of the certificate. The certificate holder is not responsible for the safety of the product(s) or for any damage or injury caused by the product(s). The certificate holder is not responsible for the safety of the product(s) or for any damage or injury caused by the product(s). The certificate holder is not responsible for the safety of the product(s) or for any damage or injury caused by the product(s). The certificate holder is not responsible for the safety of the product(s) or for any damage or injury caused by the product(s).



You have been awarded:
Intertek WH US + C Mark for Fire Window Frames
Standards: UL 10C (1985), NFPA 252 (1995), UL 9 (2005), CWI 156 (1984), USC 14 (1986)

Certificate number: WH13-2353902

Organization: Aldrees Industrial & Trading Co. (ALITCO)
P.O. Box 15273
Riyadh 11444
Kingdom of Saudi Arabia

Product: Steel Tech 45 Min Steel Fire Window whose P/HP
See ID 3408
Fire Rating: 45 Min Insulated Pressure, 20 Min without Pressure, 20 Min without Pressure
Using Information See following pages

Certification body: Intertek Testing Services NA, Inc.
Initial registration: January 01, 2013
Date of expiry: December 31, 2022
Issue status: 5

Authorized By:
Jean-Philippe Kayl
Jean-Philippe Kayl, Director of Certification

Intertek Testing Services NA, Inc.
545 E. Gillespie Road, Ste M, Alhambra Heights, IL 60005 USA
Phone: 631-439-3587 Fax: 631-439-7329

www.intertek.com

This certificate is only valid when used in conjunction with the product(s) specified on this certificate and is not a substitute for the product's technical specifications. The holder of this certificate is responsible for ensuring that the product(s) remains in compliance with the requirements of the certificate. The certificate holder is not responsible for the safety of the product(s) or for any damage or injury caused by the product(s). The certificate holder is not responsible for the safety of the product(s) or for any damage or injury caused by the product(s). The certificate holder is not responsible for the safety of the product(s) or for any damage or injury caused by the product(s). The certificate holder is not responsible for the safety of the product(s) or for any damage or injury caused by the product(s).

CERTIFICATE OF COMPLIANCE

Certificate Number 20151231-R38603
Report Reference R38603-20151230
Issue Date 2015-DECEMBER-31

Issued to: ALDREES INDUSTRIAL & TRADING CO
Po Box 15273
Riyadh 11444 SAUDI ARABIA

**This is to certify that
representative samples of**

SWINGING-TYPE FIRE DOORS, POSITIVE-PRESSURE
TESTED

A single and pair of swinging-type fire door assembly of the
hollow metal type with mineral wool core, rated up to and
including 3 and 2 hr., respectively.

Have been investigated by UL in accordance with the
Standard(s) indicated on this Certificate.

Standard(s) for Safety: ANSI/UL 10C, Positive Pressure of Fire Tests of Door
Assemblies

ANSI/UL 10B, Fire Tests of Door Assemblies

Additional Information: See the UL Online Certifications Directory at
www.ul.com/database for additional information

Only those products bearing the UL Certification Mark should be considered as being covered by UL's
Certification and Follow-Up Service.

Look for the UL Certification Mark on the product.



Bruce Mahrenholz, Director North American Certification Program
UL LLC

Any information and documentation involving UL Mark services are provided on behalf of UL LLC (UL) or any authorized licensee of UL. For questions, please
contact a local UL Customer Service Representative at <http://ul.com/aboutul/locations/>



Sector Strategy At Aics

01

To provide the market with knowledge for highest technology product.

02

Our target the international market.

03

Contribute to the development of Saudi Arabia's industry.

04

ALTICO's strategy aligns with Vision 2030.



WHY
STEEL TECH ?

CERTIFICATION

GENERAL
INFORMATION'S

GAUGE
REFERENCES

D
O
O
R
S

THE "P" SERIES
POLYURETHANE INSULATED

THE "S" SERIES
FIBERGLASS OR
ROCKWOOL DOORS.

THE "C" SERIES
POLYSTYRENE DOORS

THE "ED" SERIES
EMBOSSED DOORS

THE "H" SERIES
HONEYCOMB DOORS

THE "A" SERIES
ACOUSTICAL DOORS

THE "B" SERIES
BULLETS RESISTANCE
DOORS

THE "D" SERIES
JAIL & DUTCH DOORS

THE "X" SERIES
CONTROL HARMFUL
RAYS DOORS

THE "SE" SERIES
Security doors

THE "ST" SERIES
STAINLESS STEEL DOORS

THE "T" SERIES
THERMAL BREAK DOORS

F
R
A
M
E
S

MW SERIES

GM & GD SERIES

DW SERIES
SLIPS ON

DE SERIES

OUR CLIENTS

OUR PROJECT

Why Steel Tech ?



ISO 2001: Steel Tech is complied with the world recognized interntional Codes and Standards like:
Hollow metal manufacturers association (HMMA)
National Fire protection association (NFPA 80,101)
ASTM E152-81a



Intertek Standard:
ASTM E152-81a, UBC 7-2 (1997), UBC 7-2 (1994), UL 10(b) (1997),
CAN / ULC S104 1980 (R1985), UL 10(c) (R2001), CAN / ULC S104
(2010)



Underwriting Laboratory (UL) Standard:
ANSI/UL 10C, Positive Pressure of Fire Tests of Door Assemblies
ANSI/UL 10B, Fire Tests of Door Assemblies



Saudi Made.

General Information's

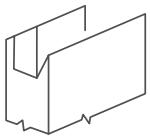

01

Doors are closed top and bottom side with "U" shape channel flush on the top and inverted on the bottom side.

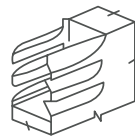

02

Vertical Edges are hairline seam "invisible from the face of the door"

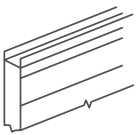

03

All Doors are supported by door close reinforcement "2mm with width of 400 mm

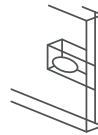

04

Lockset preparation for the most common hardware "European or ANSI

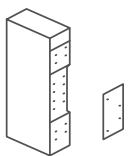

05

Hinge reinforcements are complied with ANSI 156.7 4.5mm steel non-handed.



06

Overlapping Astragal "Optional" 3mm steel plate fix with active leaf

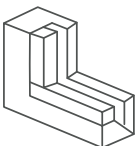

07

Glazing trim standard

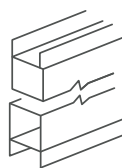

08

Louvers as per the specifications pierced louver if its not fire rated doors or cutout when it's required to be certified as fire doors "approved fire rated louver will be required "



General Information's

01

Doors are closed top and bottom side with "U" shape channel flush on the top and inverted on the bottom side.

03

All Doors are supported by door closer reinforcement "2mm Or more with width of 400mm"

05

Hinge reinforcements are complied with ANSI 156.7 4.5mm steel non-handed.

07

Glazing trim standard

02

Vertical Edges are hairline seam "invisible from the face of the door"

04

Lock Preparation Gov.160/161 Cylindrical type (ANSI A115.2), 70MMBACKSET
OTHER TYPES AVAILABLE.

06

Overlapping Astragal "Optional" 3mm steel plate fix with active leaf

08

Louvers as per the specifications pierced louver if its not fire rated doors or cutout when it's required to be certified as fire doors "approved fire rated louver will be required "

Door Designs

Flush
(F)



Narrow Lite with
(NL)

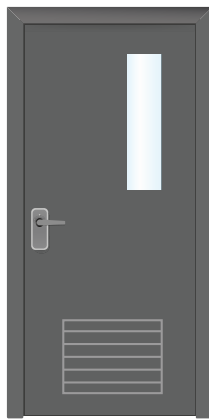

Louver
(L)



Vision with LOUVER
(VL)

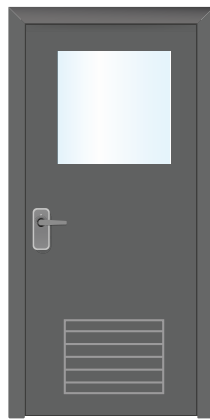

Full Vision
(FV)

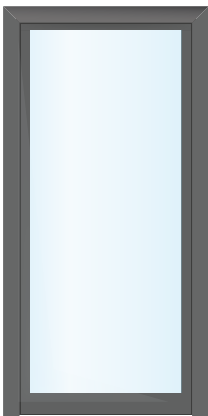

Full Louver
(FL)

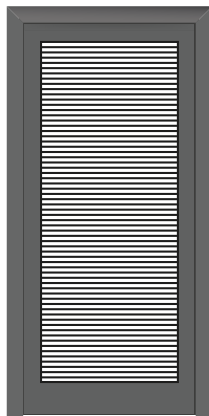

Narrow Lite
(N)



Embossed
(EM)



Steel Doors Design

Quick Reference Chart

The table lists the various classifications of doors, their gauges and some of the more typical applications for each type of door. For more information, consult SDI publication SDI-108, Recommended selection and usage Guide for Standard Steel Doors.

Steel Door Institute's Levels and Models of Hollow Metal Doors

Level	Model	Construction	Gauge	Typical Uses
01 Standard Duty	Model 1	Full Flush (seamed)	20	Apartment, Dormitory, Hotel and Motel Unit Entrance; Bedrooms, Bathrooms, Closets
	Model 2	Seamless	20	
02 Heavy Duty	Model 1	Full Flush (seamed)	18	Main Entrances to Apartment, Dormitory, Hotel and motel Building; Storage and Equipment Rooms
	Model 2	Seamless	18	
03 Extra Heavy Duty	Model 2	Full Flush (seamed)	16	Main Entrances to Schools, Office and Industrial Buildings; Stairwells Storage and Equipment Rooms
	Model 1	Seamless	16	
	Model 3	Stile and Rail	16	
04 Maximum Duty	Model 1	Full Flush (seamed)	14	Main Entrances to Schools, Office and Industrial Buildings; Gymnasiums and Locker Rooms
	Model 2	Seamless	14	

*Level 1 door can be either 1-3/8' or 1-3/4' thick.

Gauge References:

Gauge 20	1.0 mm
Gauge 18	1.25 mm
Gauge 16	1.5 mm
Gauge 14	2 mm

The "P" Series (Polyurethane Insulated)

- | "P" Series Door are constructed with a technology of hairline seams on vertical edge are not visible on face of the door.
- | Doors are specified as "Seamless" will not have vision of seams on face and vertical edges.
- | "P" Series Doors are injected with foam-in-place "Polyurethane" supporting the face of the door. Foam is entirely filling the door cavity and is chemically bonded to all interior surfaces.
- | "P" Series are injected by the foam with density exceeds 36KG/m³

METAL SHEET THICKNESS

Frame is constructed by a galvanized sheet comply with ASTM A653: 1995 with a thickness of:

- | 1.50 mm
- | 2.00 mm
- | 3.00 mm

Leaf is constructed by a galvanized sheet comply with ASTM A653: 1995 with a thickness of:

- | 1.25 mm
- | 1.50 mm
- | 2.00 mm

WHY "P" SERIES?



Polyurethane insulation increases insulative efficiency. The foam expands to cover all the door's inner space it doesn't leave any gaps at all.



Ability for isolating heat from a place to another.

Flush
(F)



Narrow with
Louver (NL)

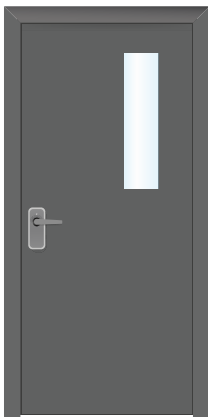

Louver
(L)



Embossed
(EM)



USAGE OF "P" SERIES

This series is common for general use like:



Unit
Entrance



Closet
Doors



Bedrooms



Bathrooms



Stairwell

FIRE RATED STANDARD

Intertek: Up to 1.5 Hrs. with the following Standard

- | Standards: UBC 7-2 (1994), UL 10(b) (1997), NFPA 252 (1999), ASTM E2074
- | (2000), NFPA 252 (2012)

FINISH

- | Primer Paint "Epoxy Primer"
- | Powder Coated "As per the required Ral Number"

The "S" Series (Fiberglass Or Rockwool Doors)

Flush
(F)



Narrow with
Louver (NL)



Louver
(L)



- | "S" Series Door are constructed with a technology of hairline seams on vertical edge are not visible on face of the door.
- | Doors are specified as "Seamless" will not have vision of seams on face and vertical edges.
- | "S" Series Doors are Insulated with "fiberglass or Rockwool" supported with galvanized steel 1.2mm vertical stiffener placed with in 150mm apart and welded within no more than 150mm along with their length. "Fiberglass or Rockwool" insulated in area between stiffeners.

METAL SHEET THICKNESS

Frame is constructed by a galvanized sheet comply with ASTM A653: 1995 with a thickness of:

- | 1.50 mm
- | 2.00 mm
- | 3.00 mm

Leaf is constructed by a galvanized sheet comply with ASTM A653: 1995 with a thickness of:

- | 1.25 mm
- | 1.50 mm
- | 2.00 mm

WHY "S" SERIES?



Designed for high traffic area.



Fiberglass of rockwool is acting as thermal lock



Fiberglass of rockwool is soundproof up to 28db

USAGE OF "S" SERIES

This series is common for Heavy Duty and Extra Heavy-Duty use like:



Main
Entrances
to Schools



Office and
Industrial
Buildings



Stairwells



Storage and
Equipment
Rooms

FIRE RATED STANDARD

Intertek: Up to 1.5 Hrs. with the following Standard

ASTM E152-81a, UBC 7-2 (1997), UBC 7-2 (1994), UL 10(b) (1997), CAN / ULC 5104 1980 (R1985), UL 10(c) (R2001), CAN / ULC 5104 (2010)

UL : Up to 3 Hrs. with the following Standard

ANSI/UL 10C, Positive Pressure of Fire Tests of Door Assemblies
ANSI/UL 10B, Fire Tests of Door Assemblies

Note: Mark for Category A "All doors listed in Category A are eligible to bear the "S" (for Smoke & Draft Control assemblies)"

FINISH

- Primer Paint "Epoxy Primer"
- Powder Coated "As per the required RAL Number"

The "C" Series (polystyrene Core)

- | "C" Series Door are constructed with a technology of hairline seams on vertical edge are not visible on face of the door.
- | Doors are specified as "Seamless" will not have vision of seams on face and vertical edges.
- | "C" Series Doors are insulated with polystyrene Board supporting the face of the door.
- | "C" Series are insulated by polystyrene Board with density of 36KG/m³

METAL SHEET THICKNESS

Frame is constructed by a galvanized sheet comply with ASTM A653: 1995 with a thickness of:

- | 1.50 mm
- | 2.00 mm
- | 3.00 mm

Leaf is constructed by a galvanized sheet comply with ASTM A653: 1995 with a thickness of:

- | 1.25 mm
- | 1.50 mm
- | 2.00 mm

WHY "C" SERIES?



Ability for isolating heat from a place to another.



Increased energy efficiency, soundproofing and quieter operation for residential and commercial applications

Flush
(F)



Narrow with
Louver (NL)



Louver
(L)



Embossed
(EM)



USAGE OF "C" SERIES

This series is common for general use like:



Unit
Entrance



Bedrooms



Bathrooms



Closet
Doors



Stairwell

FINISH

- | Primer Paint "Epoxy Primer "
- | Powder Coated "As per the required RAL Number"

The "ED" Series (Embossed Doors)

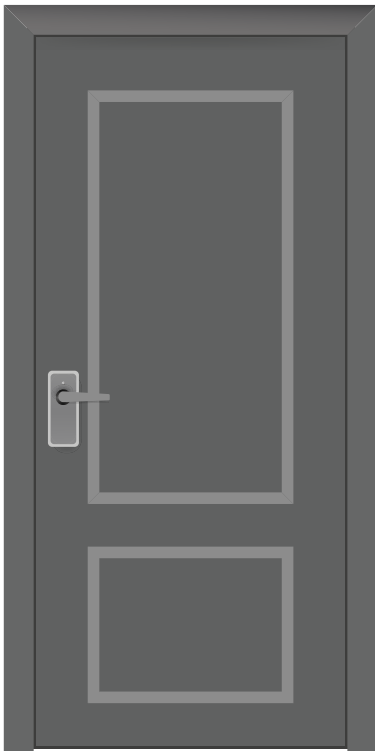

- | "ED" Series Door are constructed with a technology of hairline seams on vertical edge are not visible on face of the door.
- | Doors are specified as "Seamless" will not have vision of seams on face and vertical edges.
- | "ED" Series Doors are insulated with polyurethane supporting the face of the door.
- | "ED" Series are insulated by polyurethane with density of 36KG/m³ Metal Sheet pressed with a strong pressing machine to form the embossed design to the sheet as per the requested design.

METAL SHEET THICKNESS

"ED" series comes with to type of metal sheet:

- | Regular metal sheet "Galvanized"
- | Special metal sheet "with Wood texture painted with wood colors"

Frame is constructed by a galvanized sheet comply with ASTM A653: 1995 with a thickness of:

- | 1.50 mm
- | 2.00 mm
- | 3.00 mm

Leaf is constructed by a galvanized or Special sheet comply with ASTM A653: 1995 with a thickness of:

- | 1.25 mm
- | 1.50 mm
- | 2.00 mm

WHY "ED" SERIES?



Ability for isolating heat from a place to another.



Increased energy efficiency, soundproofing and quieter operation for residential and commercial applications



Designed combine the beauty of wood and the hardness of iron to unify the general appearance of the large complexes.

USAGE OF "ED" SERIES

This series is common for general use like:



Unit
Entrance



Bedrooms



Stairwell



Office
Entrance

FIRE RATED STANDARD

Intertek: Up to 1.5 Hrs. with the following Standard

Standards: UBC 7-2 (1994), UL 10(b) (1997), NFPA 252 (1999), ASTM E2074 (2000), NFPA 252 (2012)

FINISH

- | Primer Paint "Epoxy Primer"
- | Powder Coated "As per the required RAL Number"

The "H" Series (Honeycomb Doors)

Flush
(F)



Narrow with
Louver (NL)

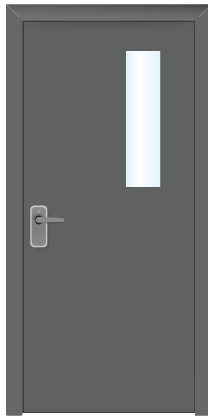

Louver
(L)



Embossed
(EM)



- | "H" Series Door are constructed with a technology of hairline seams on vertical edge are not visible on face of the door.
- | Doors are specified as "Seamless" will not have vision of seams on face and vertical edges.
- | "H" Series Doors are insulated with kraft-fiber honeycomb. Slab is securely bounded to both faces. Sheets are pressure with contact adhesive.

METAL SHEET THICKNESS

Frame is constructed by a galvanized sheet comply with ASTM A653: 1995 with a thickness of:

- | 1.50 mm
- | 2.00 mm
- | 3.00 mm

Leaf is constructed by a galvanized or Special sheet comply with ASTM A653: 1995 with a thickness of:

- | 1.25 mm
- | 1.50 mm
- | 2.00 mm

WHY "H" SERIES?



Honeycomb Core is an excellent core for all types of interior doors by virtue of their high-pressure strength.

USAGE OF "H" SERIES

This series is common for general use like:



Unit
Entrance



Bedrooms



Bathrooms



Closet
Doors



Stairwell

FIRE RATED STANDARD

Intertek: Up to 3 Hrs. with the following Standard

Standards: ASTM E152-81a, UBC 7-2 (1997), UBC 7-2 (1994), UL 10(b) (1997), CAN / ULC S104 1980 (R1985), UL 10(c) (R2001), CAN / ULC S104 (2010)

FINISH

- | Primer Paint "Epoxy Primer"
- | Powder Coated "As per the required RAL Number"

The "A" Series (Acoustical Doors)

Flush
(F)



Narrow with
Louver (NL)

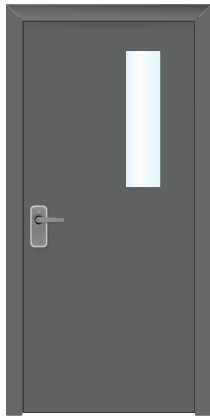

Louver
(L)



Embossed
(EM)



- | "A" Series Door are constructed with a technology of hairline seams on vertical edge are not visible on face of the door.
- | Doors are specified as "Seamless" will not have vision of seams on face and vertical edges.
- | "A" Series Doors design with vertical steel stiffener 120mm spaced on center with insulation with acoustical material.
- | Leaf available only with thickness is 54mm

METAL SHEET THICKNESS

Frame is constructed by a galvanized sheet comply with ASTM A653: 1995 with a thickness of:

- | 1.5 mm
- | 2 mm
- | 3 mm

Leaf is constructed by a galvanized or Special sheet comply with ASTM A653: 1995 with a thickness of:

- | 1.25 mm
- | 1.5 mm
- | 2 mm

WHY "A" SERIES?



Designed to control sound as a complete unit combining both Sound control and bear the pressure of use

USAGE OF "A" SERIES

This series is common for general use like:



Meeting
Rooms



Executive
Offices



Hospitals



Electric
equipment
Rooms



Lecture
Halls



Theaters

FIRE RATED STANDARD

Intertek: Sound Transmission UP 35 STC following Standard ASTM E 413-10
Classification for Rating Sound Insulations ASTM E 90-09 & 45 STC as per
Engineering Evaluation/ Assembly Report "Acoustic Logic Lab"

FINISH

- | Primer Paint "Epoxy Primer"
- | Powder Coated "As per the required RAL Number"

The "B" Series (Bullets Resistance Doors)



- | "B" Series Door are constructed with a technology of hairline seams on vertical edge are not visible on face of the door.
- | Hairline seams on vertical edge with seam that welded the full height of the door. And ground, filled and dressed smooth.
- | "B" Series Door's Face are supported with ARMOR plate to protect from bullets in accordance with UL752.
- | Top and bottom door edge are close with steel plate 2mm.

METAL SHEET THICKNESS

Frame is constructed by a galvanized sheet comply with ASTM A653: 1995 with a thickness of:

- | 2.00 mm

Leaf is constructed by a galvanized or Special sheet comply with ASTM A653: 1995 with a thickness of:

- | 1.50 mm

WHY "B" SERIES?



Designed to protect from bullets according to UL752.

USAGE OF "B" SERIES

This series is common for general use like:



Banks



Government
Buildings



Military



High
Security
Area

FIRE RATED STANDARD

Standard: UL752.

FINISH

| Primer Paint "Epoxy Primer"

| Powder Coated "As per the required RAL Number"

The "D" Series (Jail & Dutch Doors)

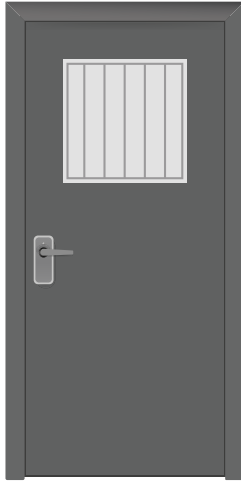

- | "D" Series Door are constructed with a technology of hairline seams on vertical edge are not visible on face of the door.
- | Hairline seams on vertical edge with seam that welded the full height of the door. And ground, filled and dressed smooth.
- | "D" Series Door's Face are supported by 2mm steel vertical stiffeners are placed no more than 75mm apart and welded no more 75 mm along their length. Top and bottom edge are closed with 3mm steel plate.
- | Door are insulated with fiberglass or rockwool in between the vertical stiffeners.

METAL SHEET THICKNESS

Frame is constructed by a galvanized sheet comply with ASTM A653: 1995 with a thickness of:

- | 2.00 mm

Leaf is constructed by a galvanized or Special sheet comply with ASTM A653: 1995 with a thickness of:

- | 1.50 mm

WHY "D" SERIES?



Doors are designed and comply with HMMA 863-98.



Doors are supplied as hinged doors or sliding as needed including their hardware as complete unit.

USAGE OF "D" SERIES

This series is common for general use like:



Jail cell doors

FIRE RATED STANDARD

Intertek: NFPA 252 (2008), UL 10(c) (2009), ASTM F1450 (2005),
NFPA 252 (2012)

FINISH

- | Primer Paint "Epoxy Primer"
- | Powder Coated "As per the required RAL Number"

The "X" Series (Control harmful rays Doors)



- | "X" Series Door are constructed with a technology of hairline seams on vertical edge are not visible on face of the door.
- | Doors are specified as "Seamless" will not have vision of seams on face and vertical edges.
- | "X" Series Doors faces are supported with Lead sheet covering the full width and height of the door and frame. The lead thickness always equals the lead used in the adjacent wall. All hardware used is lead shielded.

METAL SHEET THICKNESS

Frame is constructed by a galvanized sheet comply with ASTM A653: 1995 with a thickness of:

- | 1.50 mm
- | 2.00 mm
- | 3.00 mm

Leaf is constructed by a galvanized or Special sheet comply with ASTM A653: 1995 with a thickness of:

- | 1.25 mm
- | 1.50 mm
- | 2.00 mm

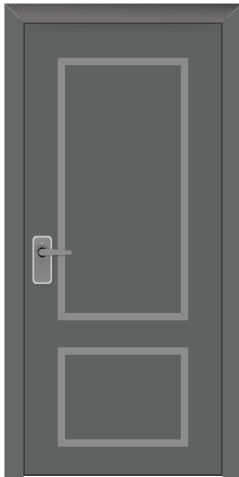

WHY "X" SERIES?



Doors are fully designed to protect from the harmful rays.

USAGE OF "X" SERIES

This series is common for general use like:



X-ray Rooms

FINISH

- | Primer Paint "Epoxy Primer"
- | Powder Coated "As per the required RAL Number"

The "SE" Series (Security Doors)

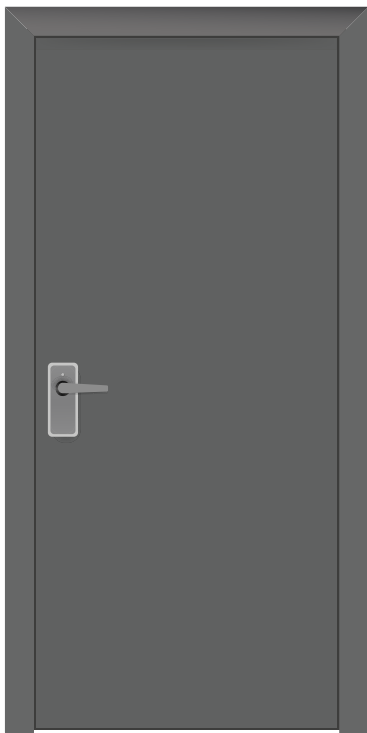

- | "SE" Series Door are constructed with a technology of hairline seams on vertical edge are not visible on face of the door.
- | Hairline seams on vertical edge with seam that welded the full height of the door. And ground, filled and dressed smooth.
- | "SE" Series Door's Face are supported by 2mm steel vertical stiffeners are placed no more than 150mm apart and welded no more 150 mm along their length. Top and bottom edge are closed with 3mm steel plate.
- | Door are insulated with fiberglass or rockwool in between the vertical stiffeners.

METAL SHEET THICKNESS

Frame is constructed by a galvanized sheet comply with ASTM A653: 1995 with a thickness of:

- | 2.00 mm

Leaf is constructed by a galvanized or Special sheet comply with ASTM A653: 1995 with a thickness of:

- | 1.50 mm

WHY "SE" SERIES?



Doors are designed and comply with HMMA 862-87.



This series is providing the maximum protection when its needed.

USAGE OF "ED" SERIES

This series is common for general use like:



To be used when
security is concern

FIRE RATED STANDARD

Intertek: NFPA 252 (2008), UL 10(c) (2009), ASTM F1450 (2005),
NFPA 252 (2012)

FINISH

- | Primer Paint "Epoxy Primer"
- | Powder Coated "As per the required RAL Number"

The "ST" Series (Stainless steel Doors)

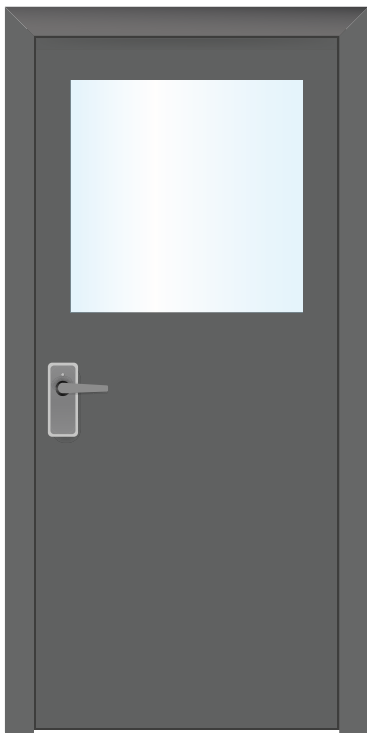

- | "ST" Series Door are constructed with a technology of hairline seams on vertical edge are not visible on face of the door.
- | Doors are specified as "Seamless" will not have vision of seams on face and vertical edges.
- | "ST" Series Doors are injected with foam-in-place "Polyurethane" supporting the face of the door. Foam is entirely filling the door cavity and is chemically bonded to all interior surfaces.
- | "ST" Series are injected by the foam with density exceeds 36KG/m³

METAL SHEET THICKNESS

Frame is constructed by a Stainless-Steel sheet:

- | 1.50 mm

Leaf is constructed by a Stainless-Steel:

- | 1.25 mm

WHY "ST" SERIES?



Ability for isolating heat from a place to another.



Doors are designed to withstand severe weather conditions.



Polyurethane insulation increases insulative efficiency. The foam expands to cover all the door's inner space - it doesn't leave any gaps at all.

USAGE OF "ST" SERIES

This series is common for general use like:



Door are used
in Humid Area



Internal and External
area when beautiful
look are required.

FIRE RATED STANDARD

Intertek: with the following Standard: UBC 7-2 (1997), UL 10(C) (1998), NFPA 252 (1999), ASTM E2074

The "T" Series (Thermal Break Doors)

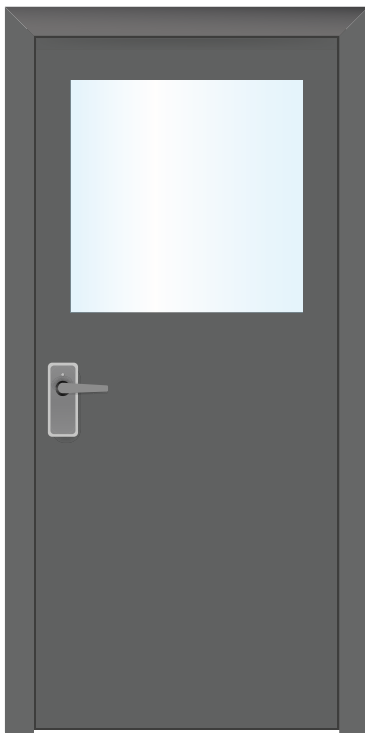

- | "T" Series Door are constructed with a technology of hairline seams on vertical edge are not visible on face of the door.
- | Doors are specified as "Seamless" will not have vision of seams on face and vertical edges.
- | "T" Series Doors are injected with Special insulation core supporting the face of the door. Core is entirely filling the door to delay the heat transferring from onside to another.
- | Top and bottom edge are close by 1.5 inverted steel sheet channel welded in place.

METAL SHEET THICKNESS

Frame is constructed by a galvanized sheet comply with ASTM A653: 1995 with a thickness of:

- | 1.50 mm
- | 2.00 mm
- | 3.00 mm

Leaf is constructed by a galvanized or Special sheet comply with ASTM A653: 1995 with a thickness of:

- | 1.25 mm
- | 1.50 mm
- | 2.00 mm

WHY "T" SERIES?



Ability for isolating heat from a place to another.

USAGE OF "T" SERIES

This series is common for general use like:



Unit Entrance



Stairwell

FIRE RATED STANDARD







Intertek: with the following Standard: UBC 7-2 (1994), UL 10(b) (1997), NFPA 252 (1999), ASTM E2074 (2000), NFPA 252 (2012)

FINISH

- | Primer Paint "Epoxy Primer"
- | Powder Coated "As per the required RAL Number"







Table 2 -

Suggested door levels and applications

Building Types	Standard Steel Door Levels				Door Design Nomenclature					
	01 Standard Duty 1-3/5 1-3/4	02 Heavy Duty 1-3/4 only	03 Extra Heavy Duty 1-3/4 only	04 Maximum Duty 1-3/4 only	 F	 G	 V	 FG	 N	 L
Apartment										
Main Entrance		•	•		•	•		•	•	
Unit Entrance	•	•	•		•					
Bedroom	•				•					
Bathroom	•				•					•
Closet	•				•					•
Setairwell		•	•				•			
Mechanical		•	•		•					•
Dormitory										
Main Entrance		•	•	•		•		•	•	
Unit Entrance	•	•			•					
Bedroom	•	•			•					
Bathroom	•	•			•					•
Closet	•	•			•					•
Setairwell		•	•				•		•	
Hotel - Motel										
Unit Entrance	•	•			•					
Bathroom	•				•					
Closet	•				•					•
Setairwell		•	•				•		•	
Storage & Utility		•	•		•					•
Medical										
Main Entrance			•			•	•	•	•	
Patient Room		•			•				•	
Setairwell		•	•				•		•	
Operating & Exam		•	•		•		•			•
Bathroom		•	•		•					•
Closet	•	•			•					
Recreation		•			•					
Kitchen		•	•							
Mechanical-Storage - Utility		•	•		•					•

Standard Steel Door Levels







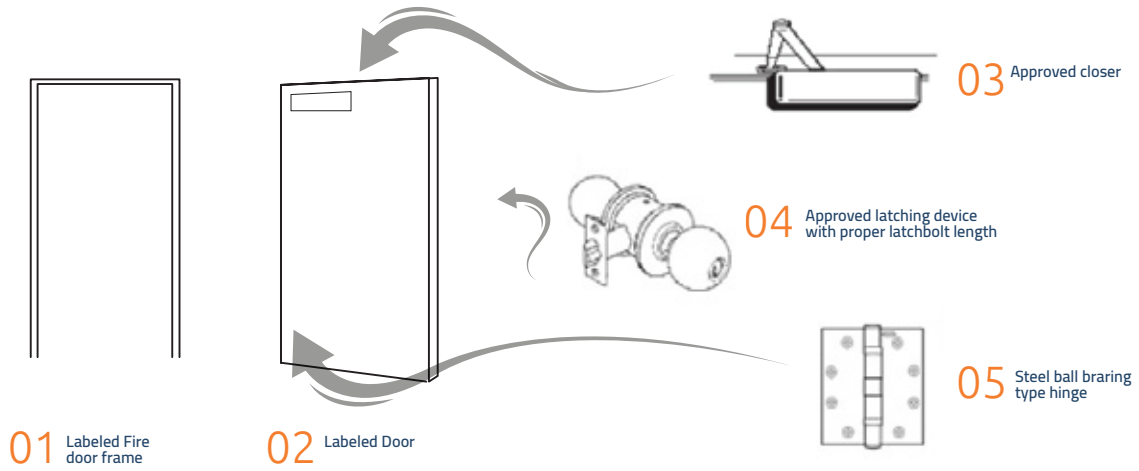

Door Design Nomenclature

Building Types	01	02	03	04	Door Design Nomenclature					
	Standard Duty 1-3/5 1-3/4	Heavy Duty 1-3/4 only	Extra Heavy Duty 1-3/4 only	Maximum Duty 1-3/4 only						
Industrial										
Entrance & Exit			•	•		•		•	•	
Office	•	•			•	•				
Production			•			•			•	•
Toilet		•	•		•					•
Tool			•	•	•					
Trucking			•	•		•				
Monorail			•	•	•					
Office										
Entrance			•			•		•	•	
Individual office	•				•	•				
Closet	•				•					•
Toilet		•	•		•					
Setairwell		•	•				•			
Equipment		•	•		•					
Boiler		•	•		•					•
School										
Entrance & Exit			•	•		•		•	•	
Classroom		•				•			•	
Toilet		•	•		•					•
Gymnasium			•	•	•	•	•		•	
Cafetria		•	•			•				
Setairwell		•	•				•		•	
Closet	•	•	•	•	•					•

Note: Table 2 is only a guide. Please consult ANSI/SDI A250.8 and applicable building codes for additional requirements. For additional designs refer to SDI-134, Nomenclature for standard steel doors and steel frames.

The five basic requirement for a fire rated opening



Opening	Wall Rating	Door and Frame Rating	Description and Uses
	4 Hour	3 Hour (180 Minutes)	These openings are in walls that separate buildings or divide a single building into designated fire areas.
	2 Hour	1-1/2 Hour (90 Minutes)	Openings of this type are used in enclosure of vertical communications or egress through buildings. Examples of these types of openings include stairwells and elevator shafts.
	1 Hour	1 Hour (60 Minutes)	These door and frame assemblies divide occupancies partitions.
	1 Hour	3/4 Hour (45 Minutes)	For use where there are openings in corridors or room partitions.
	2 Hour	1-1/2 (90 Minutes)	This opening is in a wall where there is the potential for severe fire exposure from the exterior of the building.
	1 Hour	3/4 Hour (45 Minutes)	This opening is in an exterior wall that has the potential to be exposed to moderate to light fire from the exterior of the building.
	1/2 Hour	1/3 Hour (20 Minutes)	These openings are in corridors where smoke and draft control is required .
	No fire protection rating	Smoke and draft control	These opening are in partitions required from smoke control in a building. No fire resistance rating is needed for the door assembly. The air leakage rate for the assembly cannot exceed 3.0 CFM/ft ² at 0.10 inch (0.9m ³ /min./m ² at 25 Pa).

MW Series

FOR 45mm THICK DOORS
MASONRY WALL APPLICATION

The "MW" Series frames are Knocked down (K.D.) type, Field assembled or welded Unit type with all exposed welds ground smooth. Head and jambs of K.D. frames have die-cut metered corners that interlock rigidly when filed assembled. Transoms, sidelight and borrowed lite are welded unit type with all exposed welds ground smooth. Door-stops are 16mm high. Double rabbet, single rabbet or cased opening profiles are sized to suit wall applications. Jamb anchors are available for existing opining wall conditions.

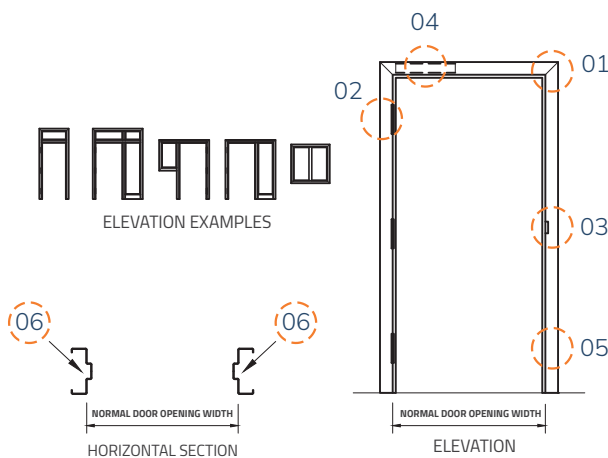

CROSS SECTION DETAILS

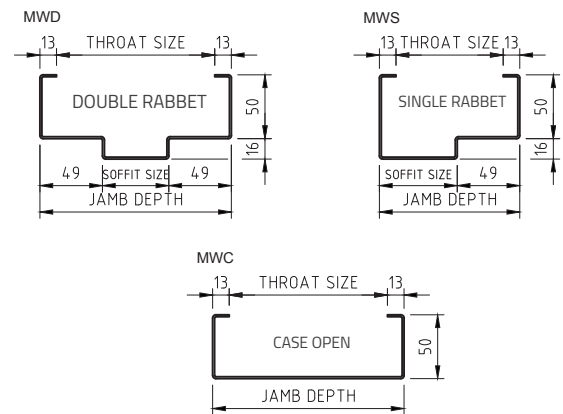

MW Series Frames Construction Features

01 KNOCKED DOWN CORNER CONSTRUCTION

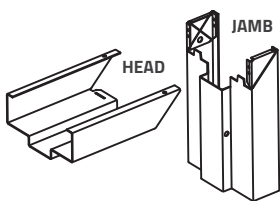

02 HING REINFORCEMENT

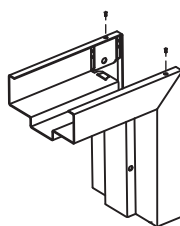

03 LOCK STIPE PREPARATION

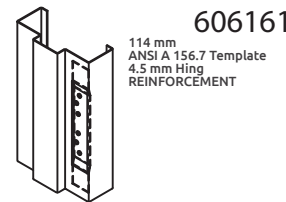

04 CLOSER REINFORCEMENT

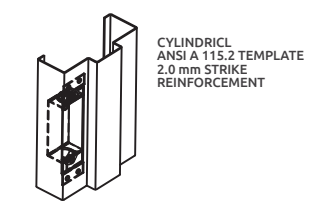

05 CLOSER REINFORCEMENT

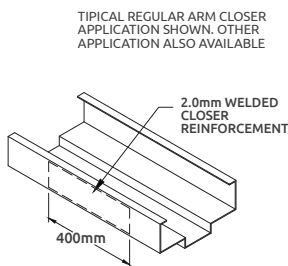

06 DOOR SILENCER (MUTE)

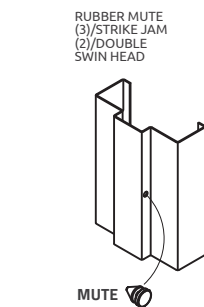

07 EXISTING OPINENG ANCHOR

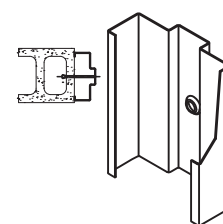

08 EXISTING OPINENG ANCHOR

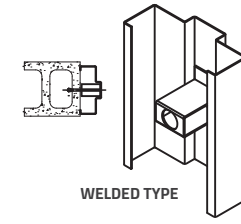

(OPTIONAL)

(STANDARD)

(OPTIONAL)

DW Series

FOR 45mm THICK DOORS
MASONRY WALL APPLICATION

The "DW" Series frames are Knocked down (K.D.) type, Field assembled or welded Unit type with all exposed welds ground smooth. Head and jambs of K.D. frames have die-cut metered corners that interlock rigidly when filed assembled. Single rabbet, double rabbet and cased opening profiles are sized to fit popular wall thickness. Integral doorstop are 16 mm high and frame face are 50mm, adjustable, compression type anchors are welded to jambs and allow frames installation, plumbing and squaring after wallboard is applied (to adjust anchors use screw drive). Components have backbend-return that protect the wall surface during installation. Sill anchoring is by means of screws through dimpled holes in face.

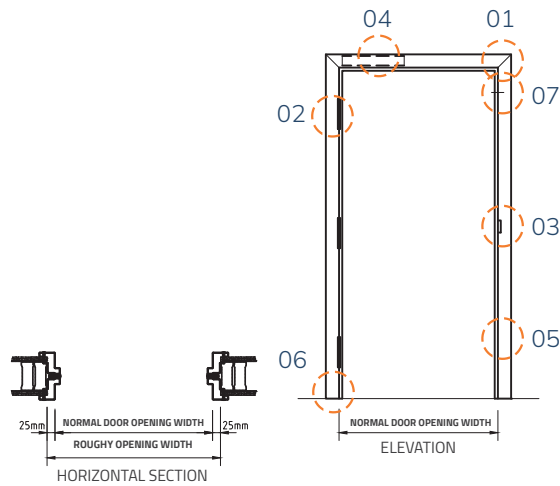

CROSS SECTION DETAILS

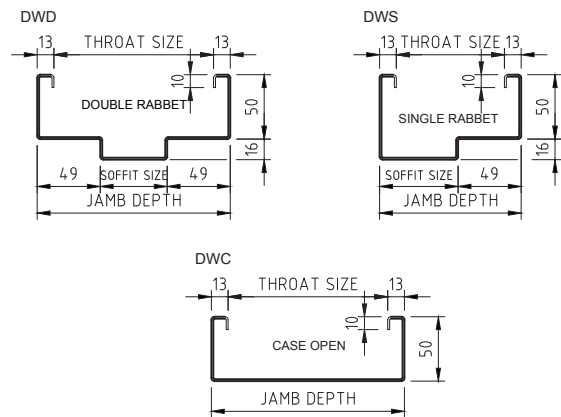

DW Series Frames Construction Features

01 KNOCKED DOWN CORNER CONSTRUCTION

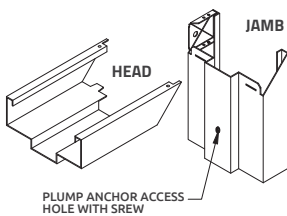

KNOCKED DOWN AFTER ASSEMBLY

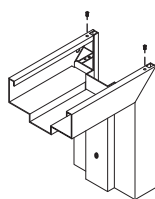

02 HING REINFORCEMENT

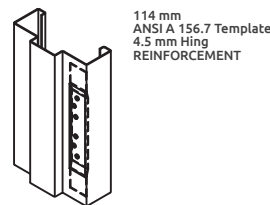

(OTHER TYPES AVAILABLE)

03 LOCK STIPE PREPRATION

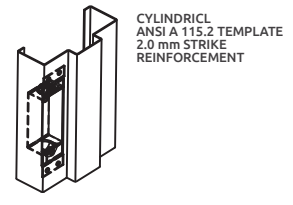

(OTHER TYPES AVAILABLE)

04 CLOSER REINFORCEMENT

TYPICAL REGULAR ARM CLOSER APPLICATION SHOWN. OTHER APPLICATION ALSO AVAILABLE

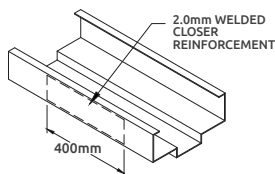

(OPTIONAL)

05 DOOR SILENCER (MUTE)

RUBBER MUTE (3)/STRIKE JAM (2)/DOUBLE SWIN HEAD

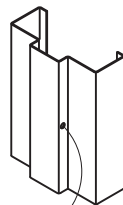

(STANDARD)

06 SILL ANCHOR

DIMPLE HOLE FOR #8 FH FASTENER BY CONTRUVTOR AND MUST BE LONG ENOUGH TO ENGAGE STUD

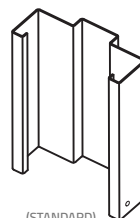

(STANDARD)

07 ADJUST ABLE PLUMP ANCHOR

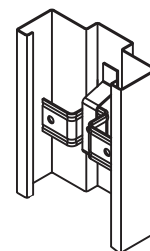

(STANDARD)

GM & GD Series

Gasketed Steel Frame
FOR 45mm THICK DOORS
MASONRY WALL &
DRY WALL APPLICATION

The "GM and GD" Series frames are Knocked down (K.D.) type, Field assembled or welded Unit type with all exposed welds ground smooth. Head and jambs of K.D. frames have die-cut metered corners that interlock rigidly when field assembled. Doorstop are 16mm high and have an integral Kreft with foam filled, fire rated, compression type gasket (weatherstrip). For "GD" Series Adjustable, Compression type anchors are welded to jambs and allow frame installation, plumping and squaring after wallboard is applied (to adjust anchors use screw drive)

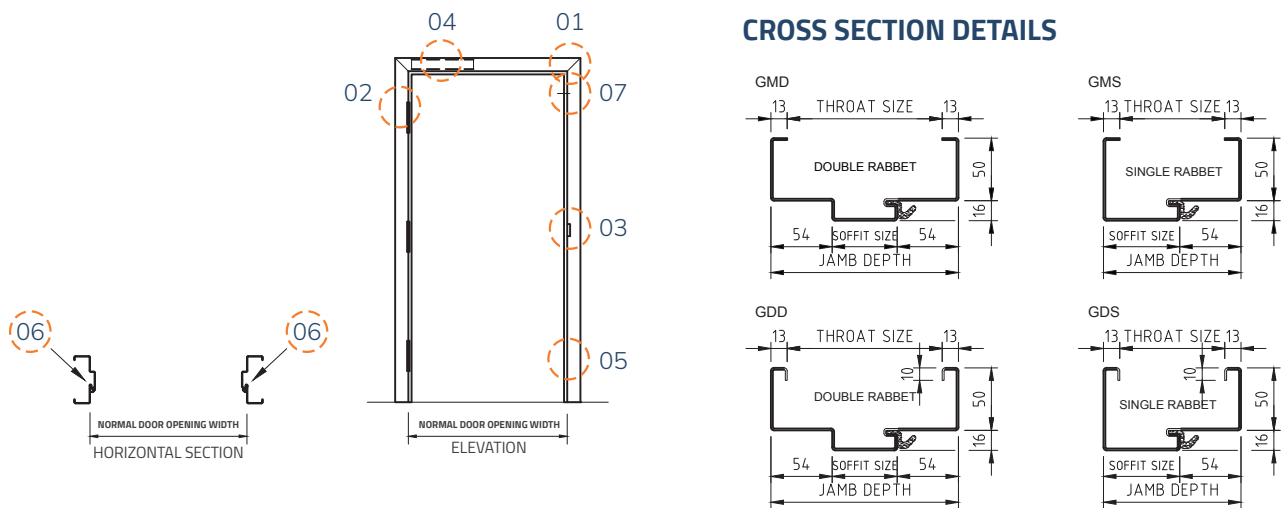

GM & GD Series Frames Construction Features

01 KNOCKED DOWN CORNER CONSTRUCTION

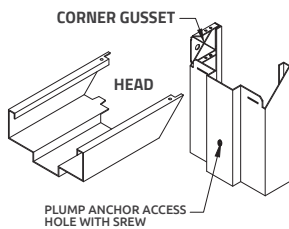

KNOCKED DOWN AFTER ASSEMBLY

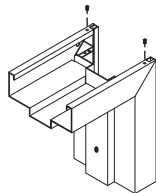

02 HING REINFORCEMENT

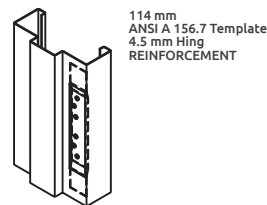

(OTHER TYPES AVAILABLE)

03 LOCK STIPE PREPARATION

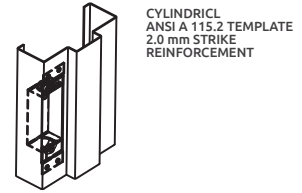

(OTHER TYPES AVAILABLE)

04 CLOSER REINFORCEMENT

TYPICAL REGULAR ARM CLOSER APPLICATION SHOWN. OTHER APPLICATION ALSO AVAILABLE

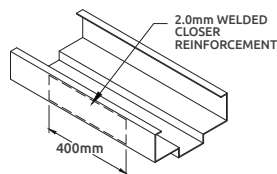

(OPTIONAL)

05 DOOR GASKET

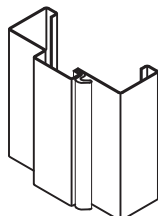

06 SILL ANCHOR

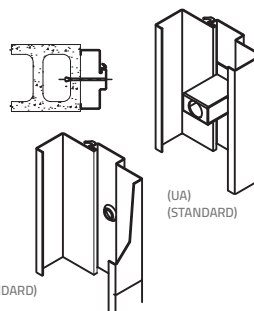

(EA) (STANDARD)

07 ADJUST ABLE PLUMP ANCHOR FOR GDD & GDS ONLY

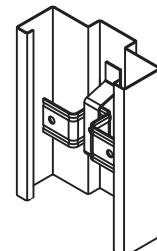

DE Series

Double Egress
Steel Frame
FOR 45mm THICK DOORS
STDR. WALL APPLICATION

The "DE" Series frames are Knocked down (K.D.) type, Field assembled or welded Unit type with all exposed welds ground smooth. Head and jambs of K.D. frames have die-cut metered corners that interlock rigidly when field assembled. Integral Doorstop are 16mm high. Frame face are 34mm and 50mm. Jamb anchors are available for existing opening wall conditions.

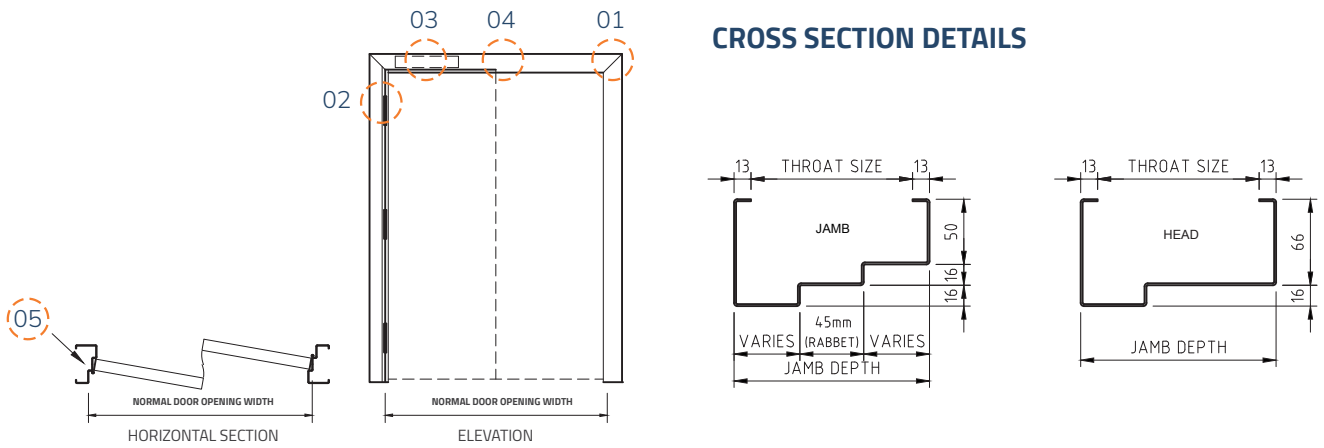

DE Series Frames Construction Features

01 WELDED CORNER

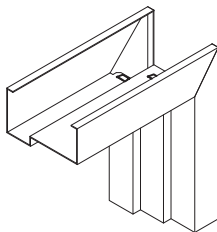

02 HING REINFORCEMENT

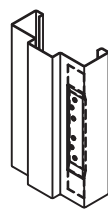

114 mm
ANSI A 156.7 Template
4.5 mm Hing
REINFORCEMENT

(OTHER TYPES AVAILABLE)

03 CLOSER REINFORCEMENT

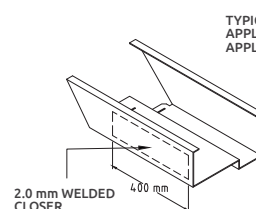

TYPICAL REGULAR ARM CLOSER
APPLICATION SHOWN. OTHER
APPLICATION ALSO AVAILABLE

2.0 mm WELDED
CLOSER
REINFORCEMENT

(OPTIONAL)

04 DOOR GASKET

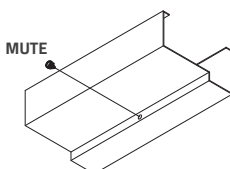

(2) PER HEAD

05 EXISTING OPENING ANCHO

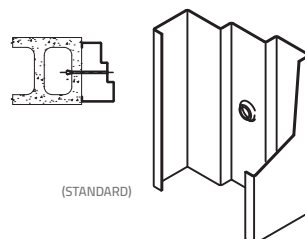

(STANDARD)

EXISTING OPENING ANCHO

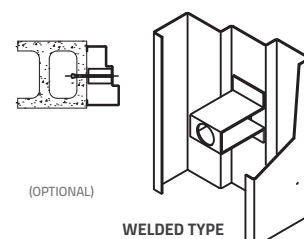

(OPTIONAL)

WELDED TYPE

Specification Section

PART 1 – General

PART 1 Articles designed to verify compliance with the product specifications

Materials
Suppliers
Installers
Manufacturers

01 SUMMARY

Statement describing the work covered in the section

Overview - no binding requirements

A. SECTION INCLUDES

Paragraph used to provide more detail

B. PRODUCTS INSTALLED BUT NOT SUPPLIED UNDER THIS SECTION

Paragraph sometimes used to identify products specified under other sections but not supplied by the section at hand

Examples:

- High-energy automatic sliding door assemblies
- Intensive Care Unit (ICU) doors
- Wandering patient systems

C. RELATED SECTIONS

There might be products, materials, and other conditions that affect, or are affected by, the products that are specified.

Some sections commonly related to door, frame, and hardware specifications:

- SECTION 04200 MASONRY UNITS
- SECTION 06100 ROUGH CARPENTRY
- SECTION 06200 FINISH CARPENTRY
- SECTION 08100 STANDARD STEEL DOORS AND FRAMES
- SECTION 08200 WOOD DOORS
- SECTION 08400 ALUMINUM ENTRANCES
- SECTION 08800 GLAZING
- SECTION 09900 PAINTING AND COATINGS
- SECTION 13850 DETECTION AND ALARM
- SECTION 16100 WIRING METHODS
- SECTION 16400 LOW-VOLTAGE DISTRIBUTION

Note: The sections listed above are from the 1995 edition of CSI's MasterFormat™. Refer to the 2004 edition of CSI's Master Format™ for the six-digit numbering system and updated section titles. The example is copyrighted. All rights reserved.

D. ALLOWANCES

- Precise details of the required product or system are not fully known at the bidding phase of the project.
- The A/E includes a description of the product or system for which the allowance is reserved.
- The actual sum of the allowance will be found on the bid form, not in the specification section.

Example: "Allow the sum stated on the bid form and in SECTION 01210 ALLOWANCES for the purchase of custom door pulls for the main entrance doors. Custom door pulls shall be formed from cast bronze to match the owner's design."

E. ALTERNATES

- Identify portions of the project that vary from the base bid.
- Alternates do not equal product substitutions.

F. UNIT PRICES

- Quality, function, features known
Quantity unknown
- Unit pricing listed on bid form, not in the specification section

1.02 REFERENCES

- List the industry standards and other applicable reference documents that are used elsewhere in the section.
- Not listed in DIVISION 1 since they have a narrow and specific application to one (or a few) section (s) rather than the entire project.
- Requirements of referenced publications listed in this article are not enforceable unless specifically invoked somewhere in the specification.

Note: The A/E usually includes the publication date of each of the referenced documents to ensure that the correct editions of each publication are used on the project.

1.02 REFERENCES

Examples of commonly referenced publications in door and hardware specifications:

National Fire Protection Association (NFPA)

- NFPA 80, Standard for Fire Doors and Other Opening Protectives.
- NFPA 105, Standard for Smoke Door Assemblies and Other Opening Protectives.
- NFPA 252, Standard Methods of Fire Tests of Door Assemblies.

Builders Hardware Manufacturers Association (BHMA)

- BHMA A156.18, American National Standard for Materials and Finishes.

Door and Hardware Institute (DHI)

- DHI, Sequence and Format for the Hardware Schedule.
- DHI, Keying Systems and Nomenclature.

Hollow Metal Manufacturers Association (HMMA)

- HMMA 810-09, Hollow Metal Doors.
- HMMA 840-07, Installation and Storage of Hollow Metal Doors and Frames.

Steel Door Institute (SDI)

- SDI A250.8, Recommended Specifications for Standard Steel Doors and Frames.
- SDI 122-07, Installation and Troubleshooting Guide for Standard Steel Doors and Frames.

Underwriters Laboratories (UL)

- UL 10B, Standard for Safety – Fire Tests of Door Assemblies.
- UL 10C, Standard for Safety – Positive Pressure Fire Tests of Door Assemblies.

Window and Door Manufacturers Association (WDMA)

- WDMA IS-1A, Interior Architectural Wood Flush Doors.

1.03 SUBMITTALS

- Contractor relies on subcontractors.
- Coordinate Section 01330 submittal procedures and submittal requirements of specific sections.
- Possible submittal formats.
 - Paper.
 - Digital.
 - Online exchange.
- Samples.
 - Full-size mock-ups.
 - Costly if overlooked.
 - Closeout submittals.
 - Operations or maintenance manuals.
 - Required later in the project.

Examples:

- Final hardware schedule.
- Final keying schedule.
- As-built elevation drawings and point-to-point wiring diagrams (riser diagrams are sometimes required).
- Operational instructions for door assemblies that are equipped with special locking arrangements.
Installation instructions and templates for hardware components (e.g., panic hardware, fire exit hardware, mortise locks and latches, door closers, and automatic door operators).
- Parts manuals for the major hardware components.
- Maintenance and cleaning instructions for the major hardware components.
- Copies of all applicable warranties.

Best practice: Gather and organize these throughout the project, and update them with corrections and changes to avoid payment delays.

1.03 SUBMITTALS PLUS SPECIFICATION SECTION

- Detailed hardware schedule
- Product data
- Wiring diagrams
- Keying schedules
- Samples
- Template information
- Door schedules
- Shop drawings

1.04 QUALITY ASSURANCE

- Used to establish criteria to participate
- Requirements listed vary from project to project, even on projects from the same A/E firm.

A.MATERIAL SUPPLIER QUALIFICATIONS

Review eligibility

- AHC, CDC, EHC, AOC.
- Location
- Warehousing, etc.
- Option to petition for exception.

B.MATERIAL SUPPLIER QUALIFICATIONS

- Used to establish criteria for installers.
- No comprehensive professional certifications for installers.
- Manufacturer or association certification example:
 - American Association of Automatic Door Manufacturers (AAADM)

C.MATERIAL SUPPLIER QUALIFICATIONS

- Material suppliers, installers, contractor
- Items to review:
 - Approved detailed hardware schedule
 - Wiring diagrams.
 - Industry standards.
 - Installation instructions.
- Materials suppliers need to be aware of requirement to participate.

D.INSPECTORS OF FIRE AND EGRESS DOOR ASSEMBLIES

- Fire and egress door assemblies inspected and functionally tested.
- Confirm compliance with applicable codes and standards.
- Credentialed.
- Third-party inspector.

E.FIRE-RATED DOOR ASSEMBLIES

- Establish minimum requirements for doors, frames, and hardware.
- Reference NFPA 80.
- Fire exit devices restricted to installation on fire door leaves with label stating "Fire Door To Be Equipped With Fire Exit Hardware".
- Confirm latch meets same standard as fire-rated locking hardware.

1.05 DELIVERY, STORAGE, AND HANDLING

How products are packaged, marked, shipped, delivered, and stored

A. MARKING AND PACKAGING

- Marked to facilitate installation.
- Mark non-keyed items with respective hardware sets.
- Mark keyed products with door opening numbers.
- Packaged to protect from damage.
- Crated palletized or wrapped.

B. JOB SITE DELIVERY

- Limited hours possible.
- Phased to construction schedule.
- Examples: frames installed in masonry walls, exterior door leaves and hardware, interior door frames, door leaves, and hardware.
- Drop-ship limitations.
- Material handling.

C. STORAGE

- Environmental protection.
- Different for various products.
- Contractor instruction necessary.
- Theft
- May include hardware room.
- Material handlers on jobsite.
- Reduces claims of shortages and loss.
- Material handlers on jobsite.
- Reduces claims of shortages and loss.

1.06 WARRANTY

- Warranty periods in excess of the minimum warranty
- Implied warranty start begins upon the date of substantial completion

Warranty vs. Guaranty

- Guaranty: Separate contract by third party assuming responsibility in case the principal fails to perform.
- Warranty: Assurance by principal to assume stipulated responsibilities for completed project portions.
- Manufacturer warrants its products.
- Contractor provides a third-party guaranty for those same materials. Contractor provides a warranty for the contractor's workmanship in installing products.

Types of warranties:

- Implied warranty – Nothing in writing.
- Limited warranty – Provided in writing; limited conditions (e.g., pro-rated coverage over the term of the warranty period).
- Full – Provided in writing and covers the lifetime of the product(s).

Differences and limitations:

- Product warranty insufficient
- Labor may not be included
- Manufacturer limited warranty
- Split warranties
- Pro-rated warranties
- Discrepancies identified to A/E

Factory





Hardware

- **Hinge Meets ANSI A156.1 Grade 1 and 2**

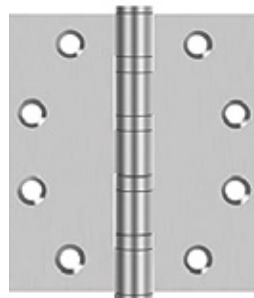
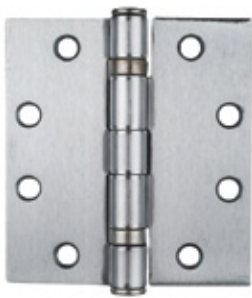

- **Door Closer Meets ANSI A156.4 Grade 1 and 2**



- **Cylindrical Lock Meets ANSI A156.2 Grade 2**



- **Dead Bolts Meets ANSI A156.5 Grade 2**



● Mortise Lock Meets ANSI A156.13 Grade 1

Mortise ANSI code	Cylindrical ANSI code	Function Lable	Description
F01	F75	Passage	Doors that don't require locking
F02 (F19)	F76	Privacy	Latchbolt by knob or lever on either side. projected deadbolt locks outside trim. Anti-panic operation. Emergency key outside
F04	F82	Entrance/ Office Lock	For office where lock is required. Operated by key outside, button on face of lock inside with passage function.
F05	F84	Classroom Lock	Classroom/Office or Utility Room. Key locks/unlock outer knob or lever. Inside always free.
F07	F86	Storeroom Closet Lock	Outside Knob/lever always rigid. Key require for entry. Inside always free rotating.
F08	F81	Entrance/ Storeroom	Latchbolty by knob or lever both sides. Deadbolt by key outside, thumbturn inside.
F09	F88	Apartment Exit	Office & Apartment Building. Lavatory Door. Outer knob/lever set by inside. Outside by operates latchbolt.
F09	F88	Entrance/ Appatment	Deabbolt by key outside, thumbnurn inside with passage function and anti-panic deadbolt operation. Deadlocking latchbolt.
F13	F90	Dormitory	Deadlocking latchbolt operated by either knob or lever. Thumbturn inside throws deadbolt and automatically locks outside knob or lever. (Anti-Panic cooperation)
F15	F93	Hotel/ Motel	Deadlocking latchbolt. Outside knob/lever always rigid. Inside knob or lever operates both deadbolt and latchbolt (Panic Function) Deadbolt by inside Thumbturn, indicator on keyed side.
F16	E2141	Deadlock	Deadbolt by key both side.
F17	E2151	Deadlock	Deadbolt by key outside, thumbturn inside.
F18	E2161	Deadlock	Deadbolt by key outside only.
F20		Entrance/ Appatment	Latchbolt by knob or lever. except when stop-work activator set. Deadbolt by key. Thumbturn inside. Anti-panic deadbolt operation.
F21	F82	Entrance Storeroom	Latchbolt by knob or lever. Deadbolt by key either side.
	F87	Utility, Asylum, Institutional	Latchbolt operated by key either side only. Both knobs or levers rigid at all time.

● **Mortise Lock Meets ANSI A156.13 Grade 1**



● **Hardware.**

Sash Lock



PANIC



ENTRANCE



PRIVACY



DEADLOCK



CLASSROOM



PASSAGE



ROLLER



STOREROOM

- **Exit Device Meets ANSI A156.4 Grade 1**



By:



+966 112 500 600

info@alitcogroup.com

KSA - Riyadh, P.O Box 2049 – 11451

www.alitcogroup.com

شركة الدرييس للصناعة والتجارة (البتكو)

AIDrees Company for Industry & Trade (ALETCO)